

# GSG4 Joint

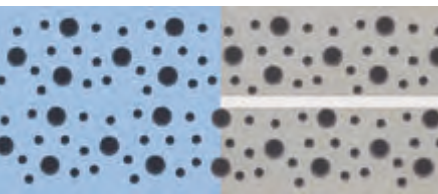

Acoustic Design  
Ceilings



## The Evolution *in Compound Seam Technology*

GreatSwiftGenius–  
with 4 sturdy butt edges

with air purification  
effect as a standard  
feature

## The Evolution of the Compound Seam

For the installation of seamless acoustic ceilings, the compound seam has become established in the market with all its strengths and weaknesses.

Therefore, Vogl Deckensysteme decided that there is room for improvement.

By means of high-precision panel production and newly defined accuracy, Vogl Deckensysteme has developed a quick compound seam for acoustic ceilings to meet market requirements.

The result is impressive – the new GSG4 Joint. From practical experience – for practical use!



### Advantages of the GSG4 Joint system:

Surrounding rebate of acoustic design panel allows quick installation and easy joint finishing:

- Less waste at borders due to 4-side edge design
- Factory primed edges – ready for finishing
- Sturdy butt edges without any weak points
- Finishing possible with all common fillers in compliance with manufacturer's instructions

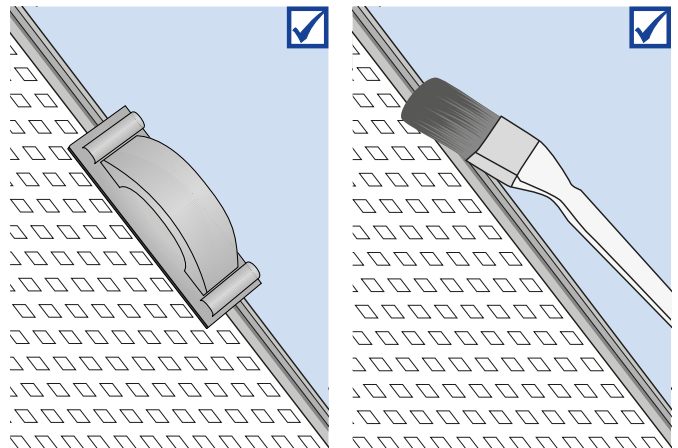
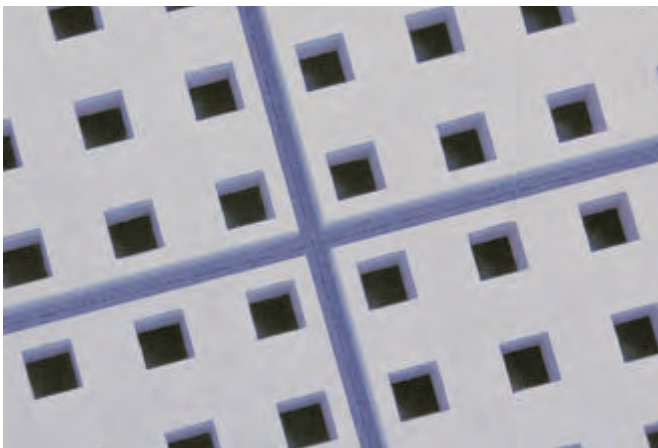

To achieve an optimum of time saving on site, every labour-saving feature helps.

GSG4 edges are, therefore, factory-primed and cardboard edges slightly chamfered.

For quick and easy installation on site – a solution from practical experience for practical use!

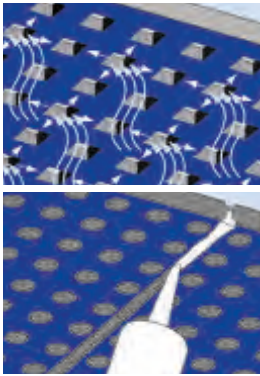







Vogel acoustic design panels of the GSG4 system are perforated ceiling panels with high acoustic performance and air purification effect (adsorption).

Black or white acoustic fleece backing (other fleece colours on request).

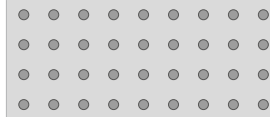
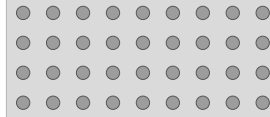
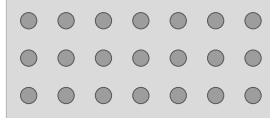
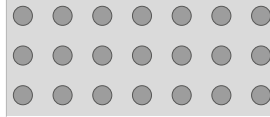
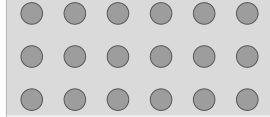
Other available options: Acoustic design panels with non-perforated edges, block perforation, applications, manufacture in accordance with customer designs and ceiling plans.

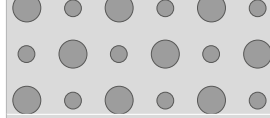
**Based on standard:** EN 14190 "Gypsum plasterboard products from reprocessing"  
**Fire rating:** A2-s1, d0 (non-flammable) according to EN 13501-1  
**Long edge:** GSG4 edge  
**Short edge:** GSG4 edge

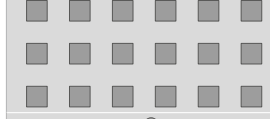

Illustration	Item number	Description	Details	m <sup>2</sup> /pallet Pcs./pallet
	LP-00390	Acoustic Design Panel GSG4 6/18R Acoustic fleece, black	1,188 x 1,998 x 12.5 mm	59.3 m <sup>2</sup>
	LP-00391	Acoustic Design Panel GSG4 6/18R Acoustic fleece, white	Perforated area: 8.7 % Mass: 9.1 kg/m <sup>2</sup>	25 pieces
	LP-00393	Acoustic Design Panel GSG4 8/18R Acoustic fleece, black	1,188 x 1,998 x 12.5 mm	59.3 m <sup>2</sup>
	LP-00394	Acoustic Design Panel GSG4 8/18R Acoustic fleece, white	Perforated area: 15.5 % Mass: 8.5 kg/m <sup>2</sup>	25 pieces
	LP-00396	Acoustic Design Panel GSG4 10/23R Acoustic fleece, black	1,196 x 2,001 x 12.5 mm	59.8 m <sup>2</sup>
	LP-00397	Acoustic Design Panel GSG4 10/23R Acoustic fleece, white	Perforated area: 14.8 % Mass: 8.5 kg/m <sup>2</sup>	25 pieces
	LP-00399	Acoustic Design Panel GSG4 12/25R Acoustic fleece, black	1,200 x 2,000 x 12.5 mm	60.0 m <sup>2</sup>
	LP-00400	Acoustic Design Panel GSG4 12/25R Acoustic fleece, white	Perforated area: 18.1 % Mass: 8.2 kg/m <sup>2</sup>	25 pieces
	LP-00402	Acoustic Design Panel GSG4 15/30R Acoustic fleece, black	1,200 x 1,980 x 12.5 mm	59.4 m <sup>2</sup>
	LP-00403	Acoustic Design Panel GSG4 15/30R Acoustic fleece, white	Perforated area: 19.6 % Mass: 8.0 kg/m <sup>2</sup>	25 pieces
	LP-00405	Acoustic Design Panel GSG4 8/12/50R Acoustic fleece, black	1,200 x 2,000 x 12.5 mm	60.0 m <sup>2</sup>
	LP-00406	Acoustic Design Panel GSG4 8/12/50R Acoustic fleece, white	Perforated area: 13.1 % Mass: 8.7 kg/m <sup>2</sup>	25 pieces
	LP-00408	Acoustic Design Panel GSG4 12/20/66R Acoustic fleece, black	1,188 x 1,980 x 12.5 mm	58.8 m <sup>2</sup>
	LP-00409	Acoustic Design Panel GSG4 12/20/66R Acoustic fleece, white	Perforated area: 19.6 % Mass: 8.0 kg/m <sup>2</sup>	25 pieces
	LP-00411	Acoustic Design Panel GSG4 8/18Q Acoustic fleece, black	1,188 x 1,998 x 12.5 mm	59.3 m <sup>2</sup>
	LP-00412	Acoustic Design Panel GSG4 8/18Q Acoustic fleece, white	Perforated area: 19.8 % Mass: 8.0 kg/m <sup>2</sup>	25 pieces
	LP-00414	Acoustic Design Panel GSG4 12/25Q Acoustic fleece, black	1,200 x 2,000 x 12.5 mm	60.0 m <sup>2</sup>
	LP-00415	Acoustic Design Panel GSG4 12/25Q Acoustic fleece, white	Perforated area: 23.0 % Mass: 7.7 kg/m <sup>2</sup>	25 pieces
	LP-00417	Acoustic Design Panel GSG4 8/15/20R Acoustic fleece, black	1,200 x 2,000 x 12.5 mm	60.0 m <sup>2</sup> *
	LP-00418	Acoustic Design Panel GSG4 8/15/20R Acoustic fleece, white	Perforated area: 9.5 % Mass: 9.1 kg/m <sup>2</sup>	25 pieces
	LP-00420	Acoustic Design Panel GSG4 12/20/35R Acoustic fleece, black	1,200 x 2,000 x 12.5 mm	60.0 m <sup>2</sup> *
	LP-00421	Acoustic Design Panel GSG4 12/20/35R Acoustic fleece, white	Perforated area: 11.0 % Mass: 8.9 kg/m <sup>2</sup>	25 pieces

\*Note: Despite being perforated irregularly, random perforation panels still yield a certain linear layout as the abutting panel edges must be non-perforated in any case. This is unavoidable and independent of the workmanship of the specialist contractor.

Block slotting										
Design	Slotting	Slots per "block"		Rim* (unslotted)		Slot area (panel)	Panel dimensions (standard size)		Centre distance (secondary profile)	Edges
		Short	Long	Short (mm)	Long (mm)	%	Width mm	Length mm	mm	
4F	5/82/15.4SL	69	4	73.9	73.3	15.7	1,200	2,400	300	GSG4
8F	5/82/15.4SL	30	4	73.9	73.3	13.7	1,200	2,400	300	GSG4
8/16F	5/82/15.4SL	4 x 6	4	73.9	73.3	10.9	1,200	2,400	300	GSG4

\*Edge dimensions refer to visible rim

Block perforation										
Design	Perforation	Holes per "block"		Rim* (non-perforated)		Perforated area (panel)	Panel dimensions (standard size)		Centre distance (secondary profile)	Edges
		Short	Long	Short (mm)	Long (mm)	%	Width mm	Length mm	mm	
4F	8/18R	64	30	41	41	12.9	1,224	2,448	312.5	GSG4
	12/25R	45	21	44	44	14.9	1,200	2,400	300	GSG4
	12/25Q	45	21	44	44	18.9	1,200	2,400	300	GSG4
8F	8/18R	30	30	41	41	12.1	1,224	2,448	312.5	GSG4
	12/25R	21	21	44	44	13.9	1,200	2,400	300	GSG4
	12/25Q	21	21	44	44	17.7	1,200	2,400	300	GSG4
32F	8/18R	13	13	41	41	9.1	1,224	2,448	312.5	GSG4
	12/25R	9	9	44	44	10.2	1,200	2,400	300	GSG4
	12/25Q	9	9	44	44	13.0	1,200	2,400	300	GSG4

\*Edge dimensions refer to visible rim

Diagrams represent visible side

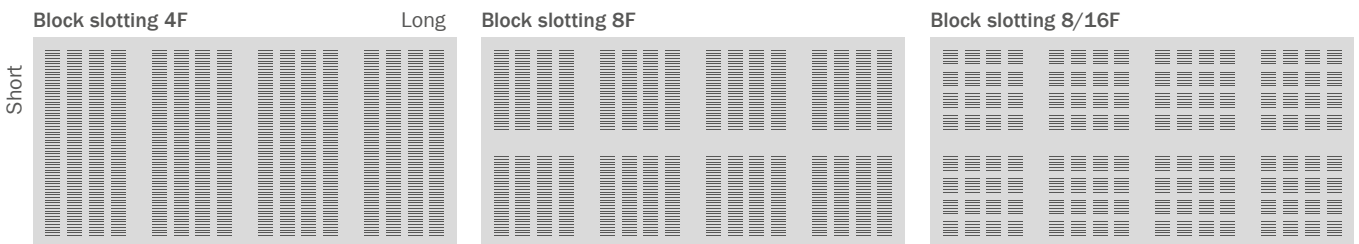

Slot only possible in longitudinal direction of the ceiling panels.

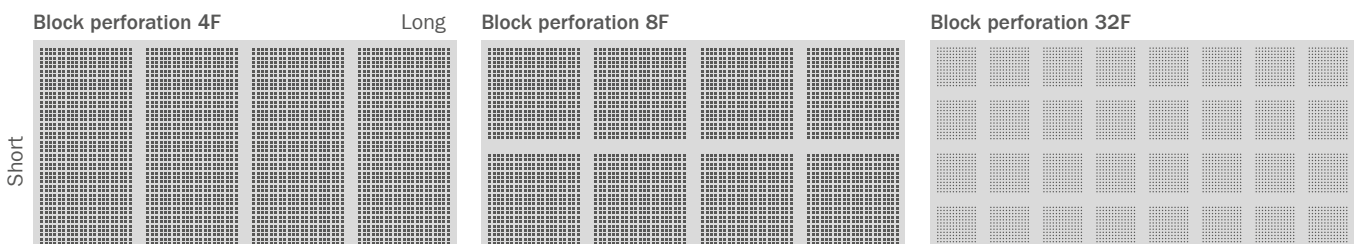

Example: 12/25Q

Example: 12/25Q

Example: 8/18R

Acoustic design panels with non-perforated rims

1 rim non-perforated

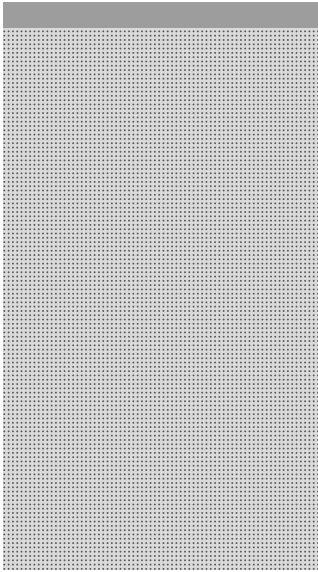

2 rims non-perforated

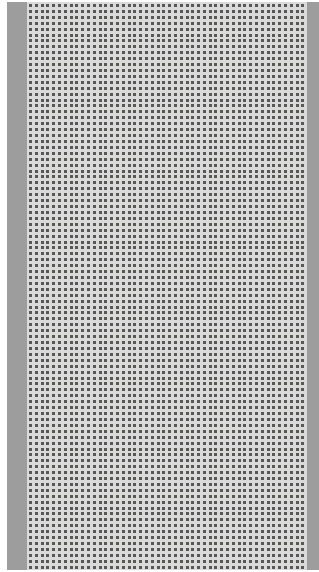

3 rims non-perforated

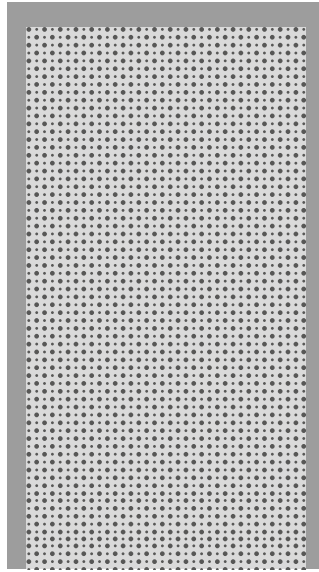

4 rims non-perforated

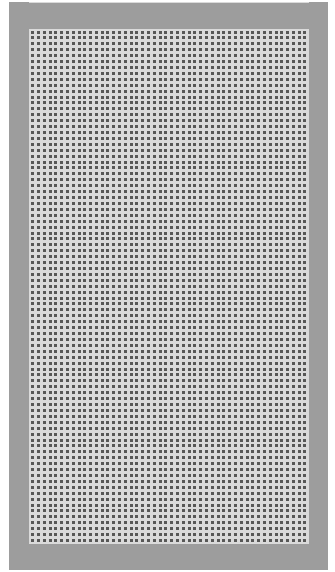

Acoustic design panels with moulded components attached

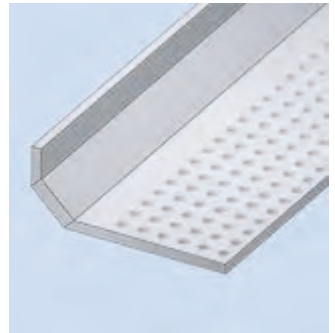
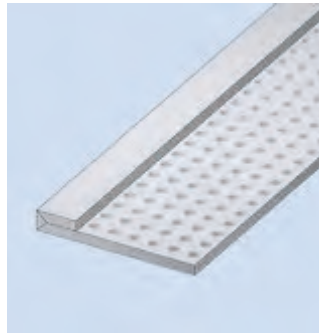
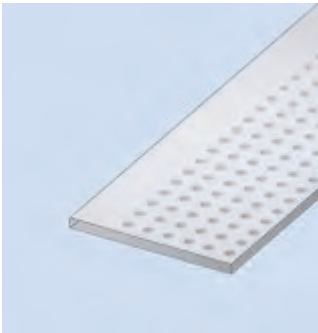

Acoustic design panels in a layout plan

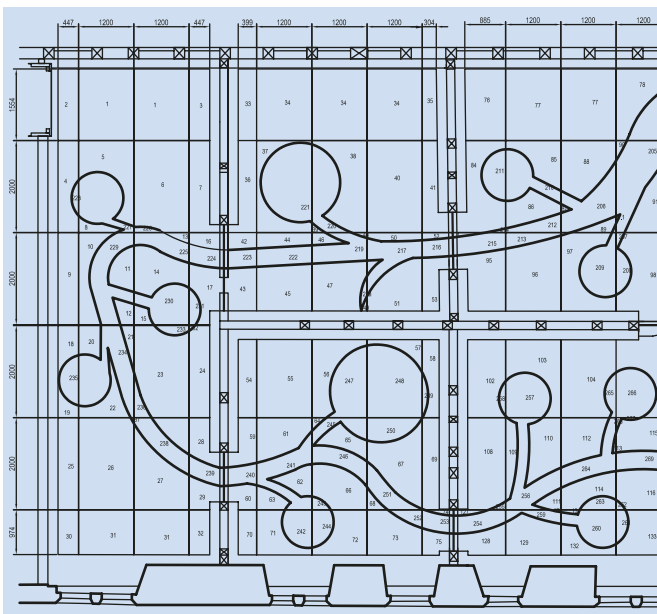

**You want a ceiling that features not only high acoustic performance, but also outstanding appearance?**

We are glad to assist you! Our experts can adapt our acoustic design panels exactly to your desired ceiling surface. When manufacturing ceiling systems to plan, we supply the custom-made and perfectly fitted acoustic design panels as well as a layout plan for use on the job site, thus ensuring reliable results for the installation. And of course, our moulded components, stretch ceilings and ceiling components can be perfectly integrated into your planned ceiling surface.



Primary profiles are hung from structural soffit with suspended brackets using fixing materials approved by relevant building authorities. Centre distance and number of suspended brackets, as well as fixation, are subject to site requirements and EN 13964/DIN 18181. CD 60/27 secondary profiles are attached to CD 60/27 primary profiles using cross connectors.

CD 60/27 are extended using straight connectors. For primary grid profiles, always ensure that joint is close to a suspended bracket (max. 100 mm). Joints should generally be staggered.

Plasterboards should be installed in accordance with EN 13964/DIN 18181 and manufacturer's guidelines.

Additional items such as lighting, ventilation, sprinkler systems etc. must be individually suspended.

Any changes in the framework owing to integrated ceiling components must be considered.

Block perforations and block slotting require different secondary profile centre distances which are shown in our tables on page 82.

GSG4 Joint framework								
Technical data	Unit	Perforated panel ceiling						
Panel thickness	mm	12.5						
Distributed load	kN/m <sup>2</sup>	≤ 0.15				≤ 0.30		
Centre distance of suspended bracket A	mm	1,150	1,050	1,000	950	900	900	750
Centre distance of primary profiles X	mm	600	800	900	1,000	1,100	600	1,000
Centre distance of secondary profiles Y	mm	see table below						

Item	Unit	Centre distance of secondary profiles Y
Acoustic Design Panel 6/18; 8/18; 8/18Q; 10/23; 12/25; 12/25Q; 8/12/50; 8/15/20; 12/20/35	mm	333
Acoustic Design Panel 15/30 12/20/66	mm	330

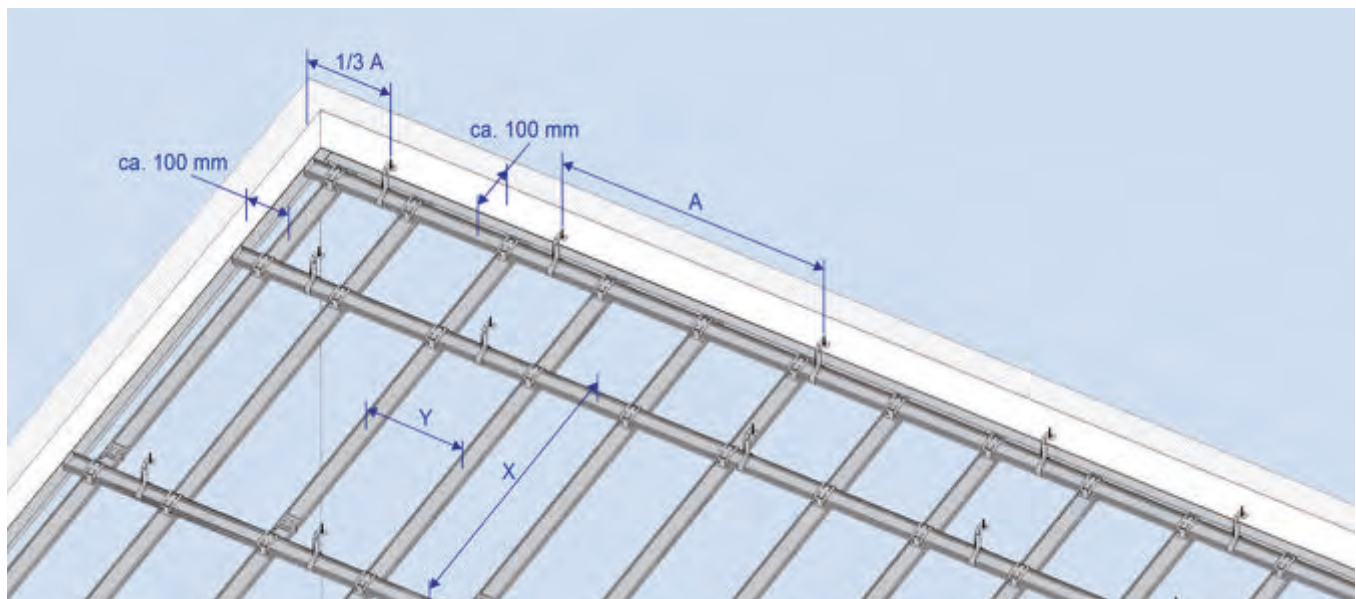

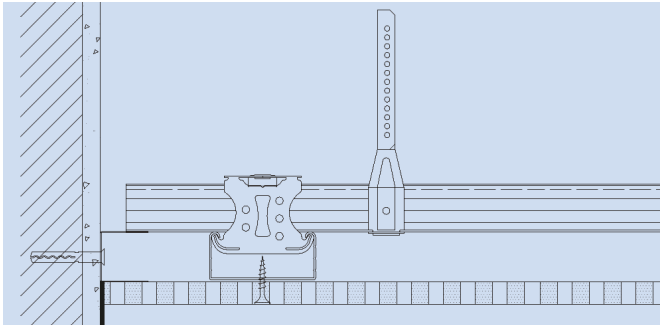

**Wall connection with filled joint:**

For filled wall connections, a double layer fleece strip is used to separate acoustic ceiling from wall.

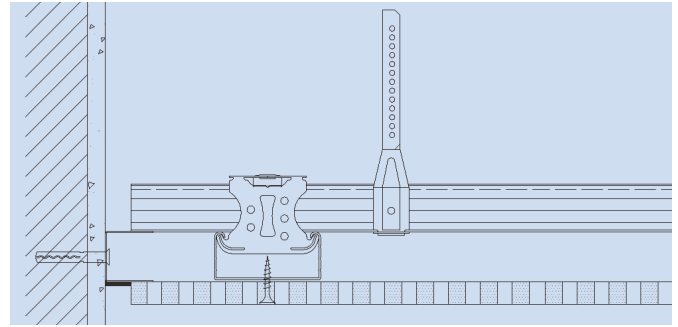

**Wall connection – shadow gap:**

For wall connections with a shadow gap, panel is placed and mounted such that desired width of shadow gap is left free. Screwing panel to UD profile is not permitted as this may be covered with a strip of adhesive double layer fleece in order to colour shadow gap.

Please contact us if you require additional technical details on possible wall connections.

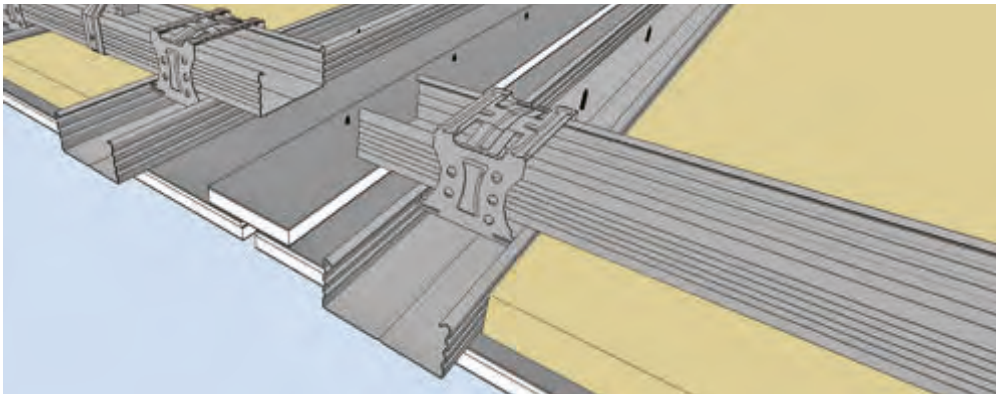

**Expansion joints:**

To reduce risk of cracking in ceiling, expansion joints should be installed every 10 linear metres / 100 m<sup>2</sup> of ceiling area.

Framework must be completely severed (see illustration) and panel strips above joint must be screwed down on one side only.

Tip: Panel strip may be covered with adhesive double layer fleece on visible side if colouring expansion joint in either black or white is desired.

Material required per m<sup>2</sup> based on a ceiling of 100 m<sup>2</sup> (10 m x 10 m, without loss or waste)

**Metal framework, suspended bracket centre distance 1,000 mm, primary profile spacing 900 mm, secondary profile spacing 333 mm**

Item number	Item description	Unit	Quantity
<b>Fixation</b>			
Standard	Safety nail, DN 6 x 35	piece	1.3
<b>Suspended brackets</b>			
See product range	Direct suspended bracket 50/120/200 and	piece	1.3
100994	Tapping screw LN 3.5 x 9.5	piece	2.6
or			
See product range	Vernier hanger / vernier bottom part and	piece	1.3
100981	Vernier security pin and	piece	1.3
See product range	Vernier top part, 200 - 2,000 mm, custom lengths on request	piece	1.3
<b>Profiles and connectors</b>			
See product range	CD profile 60/27/0.6 rK, l=XXX mm	m	4.1
PR0-00106	UD profile 28/27/0.6, 3,000 mm	piece	0.4
101595	Connector, lengthwise, CD 60/27	piece	0.8
101567	Cross connector, CD 60/27	piece	3.3
100995	Perforated panel screw SN 3.5 x 30	piece	22
<b>Joint Compound</b>			
Standard	Joint Compound	kg	0.15

Check ceiling framework for rigidity and evenness (using a straightedge).



Then check ceiling grid CD sections for centre distances and adjust, if necessary. Always mount straight connectors in a staggered manner (see figure). Measure centre distances accurately!

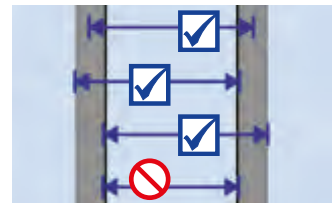
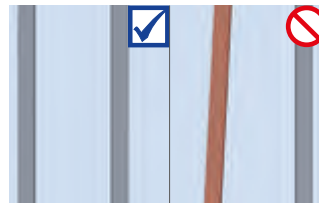
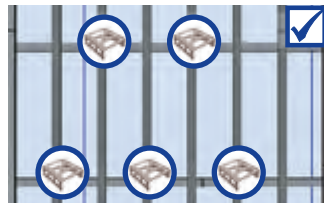

As viewed from entrance area, choose panel arrangement with short edges parallel to windows (main direction of light).



Locate centre of room to position first ceiling panel, also taking into account resulting ceiling perimeter to wall connections.



**We recommend the following accessories for installation:**

Perforated panel screws, including screw bit

**Correct handling of ceiling panels:**

- Always take into account the load carrying capacity of the building when storing ceiling panels
- Do not store ceiling panels upright, but always flat on panel pallets
- Always carry ceiling panels with short edges upright
- Protect ceiling panels from moisture; relative humidity should be 40 - 80 %
- Avoid major temperature fluctuations
- Do not expose stored ceiling panels to direct sunlight

Get panel to correct position on framework using a panel lifter if working alone, or else another worker's help.



Perforation pattern	Centre distance
Straight round perforation 6/18, 8/18, 10/23, 12/25 Offset round perforation 8/12/50, Straight square perforation 8/18, 12/25, Random perforation 8/15/20, 12/20/35	333 mm
Straight round perforation 15/30 Offset round perforation 12/20/66	330 mm

Screws must be put into panel at right angles and countersunk head screwed down to 0.5 mm below visible surface of ceiling panel.

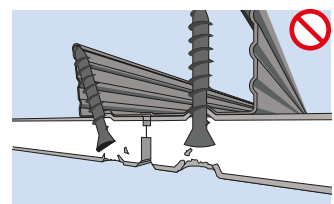
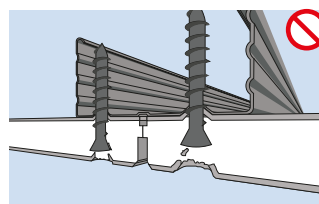
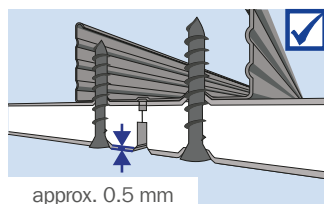

Screws should be spaced maximum 170 mm from fixing point to fixing point. Distance between screw and panel edge not to exceed 26 mm. Avoid damaging acoustic design panels by countersunk heads.

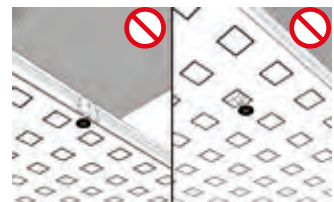
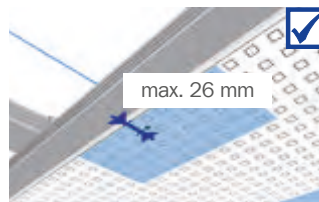
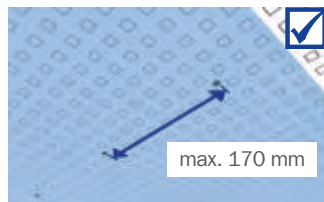

First, screw ceiling panel to framework in centre of panel, then lower panel lifter and fix a screw in centre of each short edge before finally screwing down long edges.





Take note of panel labelling (stamp) and mount in direction of reading (all stamps should point in same direction).



Install next ceiling panel edge-to-edge next to first panel. Use mounting aids **only in case of damaged butt edges** to keep proper joint size.

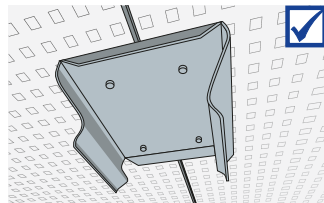

**General site conditions / Manufacturer's instructions:**

- Take movement joints of building structure into account
- Plan to include expansion joints after approx. every 10 m or approx. 100 m<sup>2</sup>
- Cardboard layer must not be penetrated by screws, but merely displaced downwards
- Working temperature should be at least +10 °C and job site temperature not below +5 °C
- Place any damping (mineral wool layer) directly onto the ceiling panels
- Carry out any additional work on ceiling (access openings, lighting recesses) immediately after installing ceiling panels and always before finishing joints

Fix screws in panel joint area using alternating pairs across panels ("zig-zag" principle), starting left or right next to screw which has already been fixed. This will create flush joint areas.

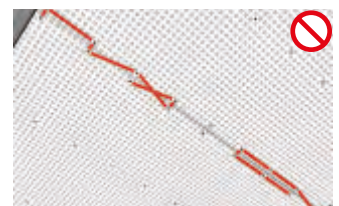
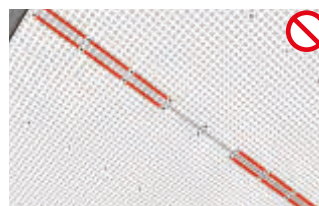
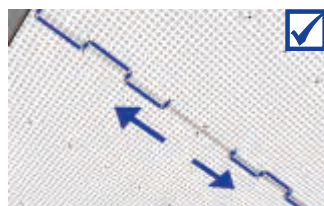

Install ceiling panels first lengthways, then crossways, resulting in cross arrangement on ceiling. Cover remaining areas in same manner, working from centre of room outwards.



Lay remaining ceiling panels edge-to-edge, always checking that joints are level and using "cross joint" system only.

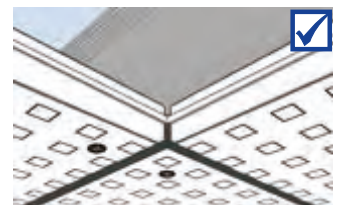

After all panels have been installed, recheck that all joints are level and adjust, if necessary, using a screwdriver. Then check with a straightedge.

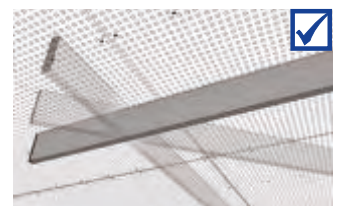
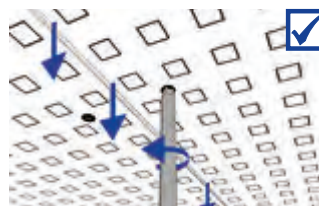

Place any damping layer directly onto back of ceiling panels. Never screw into UD28 profile when mounting panels at ceiling perimeter; sliding wall connections are also always required.

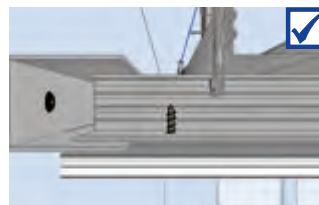

Provide for expansion joint of 5 to 10 mm every 10 linear metres / 100 m<sup>2</sup>. Additional board strip above joint must be screwed down on one side only.

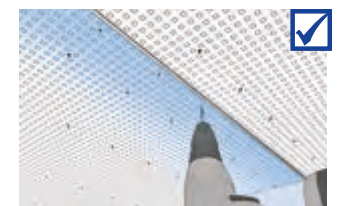
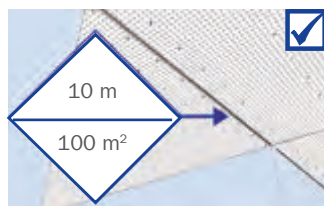

**Important!** All work that could result in damage to ceiling surface must be completed before commencing jointing.

Check ceiling, adjust any height discrepancies in joint area with a screw driver.

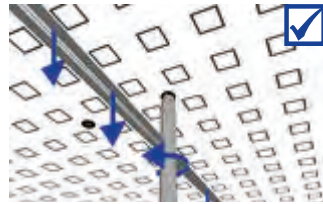

Mix joint compound in a clean pail according to manufacturer's instructions.



**General site conditions / Manufacturer's instructions:**

- Working temperature should be at least +10 °C and job site temperature not below +5 °C
- Avoid sudden heating and cooling of rooms
- Relative humidity: 40 - 80 %
- Self-levelling, cement or asphalt screeds must be fully dried – make sure there is no residual moisture
- Use joint compound as per EN 13963
- Consumption of joint compound: Approx. 150 g/m<sup>2</sup>

Load cartridge and fill joints generously holding cartridge as upright as possible to ensure complete filling of GSG4 Joint.



To achieve high GSG4 Joint strength, take greatest care to fill joint completely and use sufficient joint compound material.

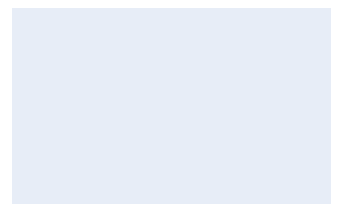
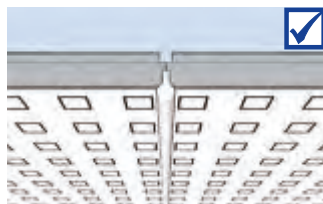

After joint compound has started to cure, and before it has hardened completely, remove any protruding material working in direction of joint.

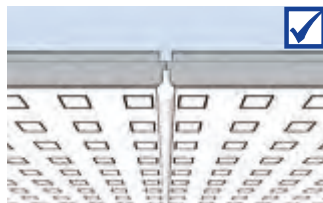

Then refill joints and screw heads with joint or finishing material, having covered perforation adjacent to joint with masking tape beforehand.

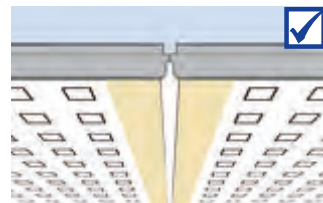

**Surface treatment for painters  
 (in accordance with ATV painting work DIN 18363)**

- Only apply coating by roller; spray application is not permitted!
- Prior to application of paint coat, a primer should generally be applied in accordance with manufacturer's specifications
- Manufacturer's recommended drying times for both primer and finishing coat must be strictly observed
- Alkaline coatings are unsuitable for plasterboards
- 3 coats of paint must be applied (1 prime coat + 2 finishing coats), and recommended drying times adhered to
- Always consult system manufacturer's technical data sheets for primers and finishing coats

Any holes closed with joint compound can be re-opened using a perforation wheel.



After joint compound has completely cured, use a handheld sander to smooth the area.

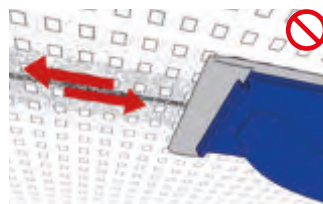
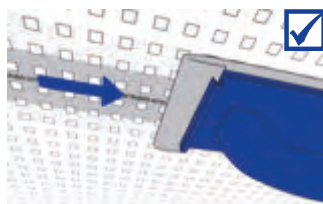

**Acoustic Design Panels**  
(with air purification effect) – GSG4 Joint system

Suspended ceiling structure, clad with Vogl acoustic design panels backed with sound absorbing fleece, mounted on a rigid ceiling framework of galvanised metal profiles, hung with horizontally and vertically aligned suspended brackets and installed using materials and fixtures approved by the relevant building authorities, with or without damping layer depending on structural requirements.

Installation in accordance with manufacturer's instructions, incl. all connection and jointing work as well as connection and fixing materials.

**System structure**

Framework in accordance with DIN 18181:2007-02

**Profiles:**

Pressure-resistant design made from galvanised sheet steel profiles CD 60/27 as primary and secondary profiles in accordance with EN 14195

**Suspended brackets:**

- Suspend with vernier systems (top part, vernier hanger)\*
- Suspend with vernier systems (top / bottom part)\*
- Suspend with direct suspended brackets\*
- Use fixing materials approved by the relevant building authorities.

**Connection:**

For primary-secondary profile connection with cross connectors, use suspended brackets and cross connectors in accordance with EN 13964.

Suspended bracket centre distance: max. 900 mm,  
Primary profile centre distance: max. 1,100 mm,  
Secondary profile centre distance: 330/333 mm\*

**Covering:**

Vogl acoustic design panels are perforated ceiling panels in accordance with EN 14190, with air purification effect, one layer 12.5 mm, laid edge-to-edge and fixed to framework using perforated panel screws SN 30, with screw spacing max. 170 mm.

Check spacing of acoustic design panels and joint sizes using appropriate mounting aids, if required.

**Perforation pattern / perforated area / mass per unit area:**

- 6/18 round / 8.7 % / 9.1 kg/m<sup>2</sup>\*
- 8/18 round / 15.5 % / 8.5 kg/m<sup>2</sup>\*
- 10/23 round / 14.8 % / 8.5 kg/m<sup>2</sup>\*
- 12/25 round / 18.1 % / 8.2 kg/m<sup>2</sup>\*
- 15/30 round / 19.6 % / 8.0 kg/m<sup>2</sup>\*
- 8/12/50 round / 13.1 % / 8.7 kg/m<sup>2</sup>\*
- 12/20/66 round / 19.6 % / 8.0 kg/m<sup>2</sup>\*
- 8/18 square / 19.8 % / 8.0 kg/m<sup>2</sup>\*
- 12/25 square / 23.0 % / 7.7 kg/m<sup>2</sup>\*
- 8/15/20 round / 9.5 % / 9.1 kg/m<sup>2</sup>\*
- 12/20/35 round / 11.0 % / 8.9 kg/m<sup>2</sup>\*

**Distributed load:**

- less than or equal to 0.15 kN/m<sup>2</sup>\*
- less than or equal to 0.30 kN/m<sup>2</sup>\*

**Fleece backing:**

Panels backed with sound absorbing fleece as:

- acoustic fleece, black\*
- acoustic fleece, white\*

**Joint finishing / filling:**

Fill screw heads with joint compound flush with surface and sand. Use joint compound as per EN 13963 to finish joints in accordance with manufacturer's instructions. Acoustic design panel edges in the GSG4 Joint system are factory primed and chamfered.

Complete system: Vogl Deckensysteme, or equivalent

\* Delete as applicable



# System Training

Our know-how for your result reliability



## Topic:

### Framework for acoustic design ceilings (“perforated ceilings”)

#### Description

A framework properly mounted to the ceiling forms the basis for a safe, flawless acoustic design ceiling that meets the regulations. In addition to theoretical fundamentals, our system training offers mainly practical guidelines for the installation work on site. Another topic of the Vogl System Training, beside suspension and connection with various components, is how to solve problems (expansion joints, integrated ceiling elements and wall connections).

#### Topics

- Installation of framework while heeding the applicable standards
- Various suspension systems and framework parts in theory and practice
- Distribution of the framework within the room
- Time and cost benefits when using Vogl framework
- Overview of the "problem solvers" in the ceiling area and their application
- Proper cutting of various profile systems
- Proper alignment of the framework by means of laser systems
- How to provide trimmers in the framework, e.g. for integrated ceiling components
- Expansion joints in the ceiling area / regulations and recommendations
- Various wall connections and their proper installation

#### Targets

**After completion of the seminar, the system training participants shall**

- understand and be able to apply current standards and regulations
- recognise and avoid typical installation errors
- use the right components when incurring problems in the ceiling installation

#### Target group

This system training is equally suited for site and project managers as well as for drywall installers and interior construction workers. Also, technically adept employees in sales or from the building material dealers' can extend their knowledge about the proper installation of ceiling structures.



A registration form is available on page 189. You have any questions in advance? We are glad to assist you! Phone: +49 9104 825-100

Registration is possible by e-mailing [info@vogl-ceilingssystems.com](mailto:info@vogl-ceilingssystems.com) directly or by fax to +49 9104 825-280. You can also find all information on training under [www.vogl-ceilingssystems.com](http://www.vogl-ceilingssystems.com)